

PHOTOTUBES TYPE UV1 UV2 UV3

FLAME SENSOR FOR GAS BURNER

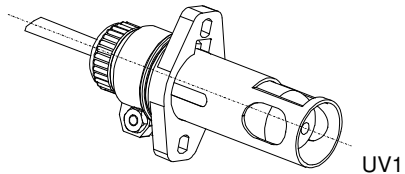

UV1

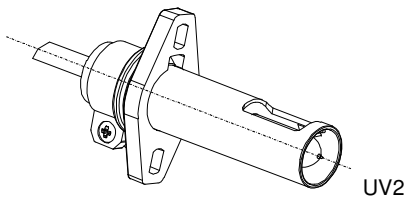

UV2

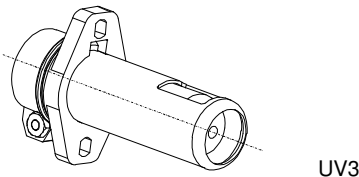

UV3

INTRODUCTION

Flame detection in burners occurs by means of sensors detecting the presence of flame through an electrical signal, which can be used by ignition and control devices. UV phototubes exploit ultra-violet radiation emitted by the light generated by the flame; they are especially suitable for appliances in which very dissimilar fuels (e.g. liquid and gaseous fuels) are used.

FEATURES

These sensors are used for flame detection in gas and mixed fuel (gas and oil) burners. UV phototubes consist of a glass bulb filled with gas, containing two electrodes suitably shaped. When supplying both electrodes with AC voltage, if an ultra-violet electromagnetic radiation (range from 190 to 290 nm) hits the phototube, the electrons, emitted by the negative biased electrode and captured by the positive biased one, start an ionization process leading to the generation of an electric discharge and hence to the production of electric current.

UV1, UV2 and UV3 are the available phototube models; their features and dimensions are explained below.

PHOTOTUBE TYPE UV1

Phototubes type UV1 are available in different sensitivity:

- Standard sensitivity
- /A : medium sensitivity
- /H : high sensitivity

The standard cable length is 655 mm, but versions with longer cables are available.

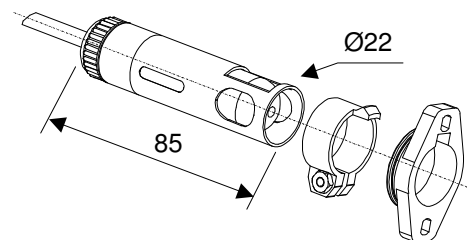

PHOTOTUBE TYPE UV2

Phototube type UV2 are smaller than phototube type UV1 (the length and the diameter of the case are smaller).

The standard cable length is 655 mm, but versions with longer cables are available.

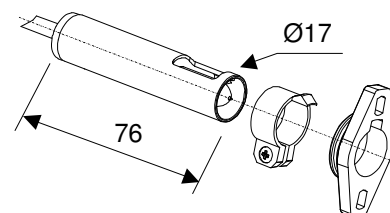

PHOTOTUBE TYPE UV3

The length and the superficial treatment of the case are the differences between the UV3 and UV1 models. The case's superficial treatment consists of a chromium plating.

The UV3 phototube has no cable which is supplied as an accessory (see fig. 1).

Models different for the sensitivity are available upon request:

- Standard sensitivity
- /A : medium sensitivity
- /H : high sensitivity

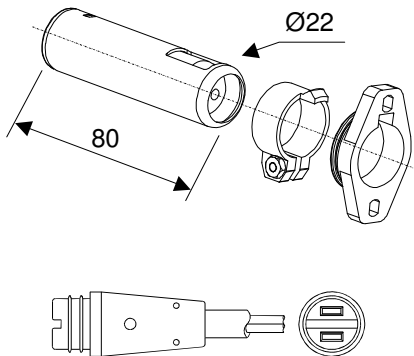

Fig. 1

The Fig. 2 shows the UV1, UV2 and UV3 drilling plane.

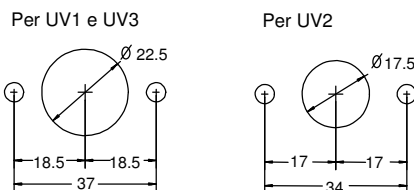

Fig. 2

CONNECTION

The blue wire is marked with number 8 because it must be connected to terminal 8 in Brahma devices series MF2, MF2.4, SR3/TR and M300 and to terminal 21 in Brahma device type MPI; Brown wire must be connected to the earth.

In Brahma device type RE3 the blue wire must be connected to the terminal number 3 and the brown wire to the terminal number 4.

DIRECTIONS FOR INSTALLATION

- Respect the applicable national and European standards EN 60335-1 and EN 60335-2-102 related to the electrical safety;
- Avoid placing detection cable close to power and ignition cables;
- In order to avoid problems due to the obsolescence of the detecting element , we recommend replacing it after about 10.000 operating hours. These flame sensors are not sensitive to the daylight, therefore if they are near to neon glow lamps or similar they need of particular screening for not to be influenced.
- Avoid subjecting the device to strong stress, impacts or falls

TECHNICAL DATA

Nominal life time:	10.000 hours (*)
Maximum distance from UV source:	1 m
UV1-3 sensor temperature range:	-20 ÷ +50 °C (*)
UV2 sensor temperature range:	-20 ÷ +60 °C

(*) *UV1 and UV3 phototubes can operating also at temperature higher than + 50 °C, in this case the sensor life time will be less than the 10.000 nominal hours.*

ATTENTION -> Company Brahma S.p.A. declines any responsibility for any damage resulting from the Customer's interfering with the device

BRAHMA SpA

Via del Pontiere,31
37045 Legnago (Vr)
Tel. +39 0442 635211 – Telefax +39 0442 25683
[http:// www.brahma.it](http://www.brahma.it)
E – mail: brahma@brahma.it

2009/03/02 Subject to amendments without notice